

Doodle Labs RM-1700-22M Mesh Rider Radio

Overview

The RM-1700-22M Mesh Rider Radio is an advanced MANET data-link. The 915-MHz and 2450-MHz bands are supported allowing it to be used globally.

The RM-1700-22M employs Doodle Labs' patented Mesh Rider® technology with state-of-the-art RF and networking capabilities that enable communication further, faster, and more reliably than any comparable solution on the market. For example, optimized video streaming carries crystal clear 4K video while simultaneously carrying low latency command and control data.

The interoperable Mesh Rider Radio platform is available in many frequency bands between 600 MHz and 6 GHz in Nano, Mini, OEM, Embedded, Wearable and External form factors. This flexibility allows customers to use their industry specific frequency bands for deploying private wireless networks that encompass all the use cases for human and machine collaboration.

For more information, please visit: <https://doodlelabs.com/smart-radio/>

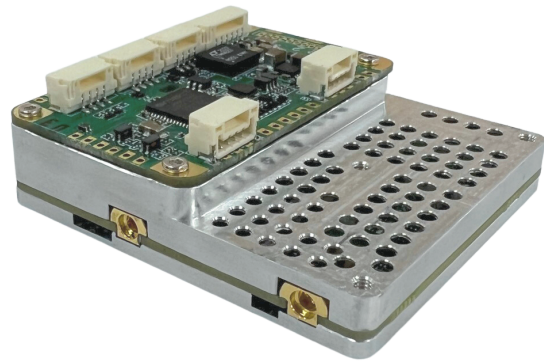

Frequency Bands

Band	Frequency Range
915-MHz	902-MHz to 928 MHz Global ISM Band
2450-MHz	2400-MHz to 2482 MHz Global ISM Band

Key Features - Mesh Rider Radio Platform

PERFORMANCE RF

- Long range (field tested >100km) and high throughput (up to 100 Mbps) Mesh Rider waveform
- Interference resistant COFDM for robust link quality in difficult RF environments
- Exceptional Multipath and NrLOS MIMO performance
- Adaptive radio modulations from BPSK up to 64QAM, with fast per packet optimization to maximize link performance in dynamic environments
- Software defined channel bandwidth for efficient re-use of spectrum
- Convolutional coding, Forward Error Correction (FEC), ACK-retransmits, Maximal Ratio Combining, Spatial Multiplexing, and Space Time Block Coding for robust data transmission over noisy channel/spectrum
- Single channel, Time Division Duplexing (TDD) for bi-directional traffic
- Resistant to high-power jamming signals
- ATPC for widely dispersed mesh network
- Built-in Spectrum Scanner to help mitigate interference issues

PERFORMANCE NETWORKING

- Ultra-Reliable Low Latency Channel (URLLC) for Command and Control
- Optimized video streaming channel for Unicast and Multicast transport
- Self-healing/self-forming multi-frequency mobile mesh for highly reliable network with redundancy
- FIPS Certified AES 256- and 128-bit encryption
- End-to-end IP architecture with Ad Hoc, WDS transparent bridge, Client, AP, and Internet Gateway operating modes
- Embedded network management APIs

ADDITIONAL FEATURES

- Very small size, weight, and power for mobile applications
- Ethernet, USB, and UART interfaces to allow easy integration into different system architectures
- Leverage the benefits of the most extensible OpenWrt ecosystem and install 3rd party IoT applications
- Rugged, vibration resistant construction to meet MIL-specs
- MIL-spec temp range (-40C to +85C)
- High quality, manufactured in ISO 9001 and ISO 14001 certified facilities
- COTS - Commercial off the Shelf
- Extended lifespan and availability

System Integration

The Mesh Rider Radio has been designed to be plug and play. Only USB and a power supply are required for integration.

Visit [Doodle Labs Technical Library](#) for extensive design-in documents.

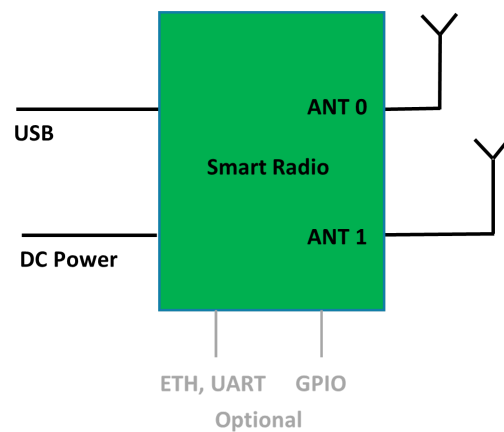

Technical Specifications (915-MHz and 2450-MHz)

Model Category	XTreme
ORDERING CODES	
Radio Configuration	2x2 MIMO
Model #	RM-1700-22M3
Antenna (Optional)	ANT-1700-3-O
Evaluation Kit (Optional)	EK-1700-22: 2x Multi-band Antenna, Breakout board, Cables
Design-In Documentation	Doodle Labs Technical Library
PERFORMANCE OVERVIEW	
Data Throughput at 10-meter range with Attached 3 dBi Antennas (Indicative)	80 Mbps (20 MHz Channel) 40 Mbps (10 MHz Channel) 20 Mbps (5 MHz Channel) 12 Mbps (3 MHz Channel)
Over the Air Data Encryption	128-bit AES (Full throughput) 256-bit AES (12 Mbps max throughput)
FIPS Certification (Optional)	FIPS 140-3
Operating Modes	Mesh, WDS AP, WDS Client Bridged or Internet Gateway with NAT
Command & Control channel	Ultra-Reliable Low Latency Channel (URLLC). Latency 1.5-10 ms
Video Channel	Optimized video streaming with Unicast and Multicast transmission
RF SPECIFICATIONS	

Protocol Compatibility	Fully compatible with Doodle Labs Mesh Rider Waveform
Frequency Range	915-MHz and 2450-MHz
Operating Bands (Software Selectable)	902-928 MHz 2400-2482 MHz
Advanced Band Filters	Dedicated SAW filters for each band for high interference immunity
Max RF Power at SMA port (Software control) Each radio individually calibrated	1.0W (30 dBm) @ MCS 0,8 0.8W (29 dBm) @ MCS 3,11 0.5W (27 dBm) @ MCS 5,13 250mW (24 dBm) @MCS 7,15
Channel Sizes (Software Selectable)	3, 5, 10, 20 MHz
Radio Data Rate	Auto adapting Modulation Coding Scheme (MCS0-15)
Antenna Signal Strength	-30 to -90 dBm (Recommended), Absolute Maximum= +12 dBm
Receiver LNA Gain	15 dB
RF Power Control	In 1 dBm steps, Tolerance ± 1 dBm
Automatic Transmit Power Control (ATPC)	Intelligently adjusts the transmit power for very close range operation
Integrated Antenna Port Protection	Able to withstand open port, >10 KV (contact) and >15KV (open air discharge) as per IEC-61000-4-2
Wireless Error Correction	FEC, ARQ
Receive Noise Figure	+4 dB
Receive Adjacent Channel Rejection (ACRR)	34 dB @ MCS0 for 20 MHz channel (Typ)

Transmitter Adjacent Channel Leakage Ratio (ACLR)	< 28 dBr (Fc ± ChBW)
Transmitter Spurious Emission Suppression	< 40 dBc
Frequency Accuracy	±10 ppm max over life
NETWORKING SPECIFICATIONS	
Mesh Router	Self-Forming/Self-Healing, Peer to Peer
Custom Software Package Manager	Image Builder, OPKG, ipk
Radio Management	Web GUI (HTTPS), SSH and JSON-RPC
Access control	Password, MAC, IP, Port filtering
Supported Protocols	IPv6, QoS, DNS, HTTPS, IP, ICMP, NTP, DHCP
Software Upgrade	Over the air software upgrade supported
HARDWARE SPECIFICATIONS	
Power Input	5V ± 5%
DC Power Consumption	<p>915-MHz: Average 7W (50% Tx/Rx duty cycle), 10W Peak Tx power @ max range, 4.5W Rx mode</p> <p>2450-MHz: Average 5W (50% Tx/Rx duty cycle), 8W Peak Tx power @ max range, 2W Rx mode</p>
Dimensions	<p>Baseband: 47 x 28 x 5 mm</p> <p>RF Board: 46 x 51 x 6.5 mm</p> <p>25-40 grams (depending on mounting configuration)</p>
Mesh Rider Antenna Ports	2x MMCX-Female Connector

Host Interface	Ethernet (100 Base-T), 1x USB -Dev (Ethernet over USB only), 1x UART (3.3V), 1x USB-H, 3x GPIO
Temperature range (Operating)	Industrial: -40°C to +85°C <i>* System's thermal design should ensure that the radio's case temperature is maintained within these specifications.</i>
Temperature range (Non-Operating)	-40°C to +100°C
Ingress Protection	IP 50, Dust Protected, No Liquid protection
Relative Humidity	5% to 95% noncondensing
Shock and Vibration Resistance	Compliant to MIL-STD-810H for high shock and vibration
Reliability	Extreme Reliability, IPC Class 2 standard with Class 3 options
Integrated CPU	MIPS 24Kc, 540 MHz, 32MB Flash, 64MB DDR2 RAM
ESD Protection	IEC 61000-4-2 test criteria, Level 3 (±6KV) for Contact Discharge and Level 4 (±15KV) for Air Discharge
MTBF	>235k hours (25 years)
Life Cycle Planning	Extended lifespan with 7 years guaranteed availability
REGULATORY INFORMATION	
J/F-12 Certification	N.A.
FCC ID	2AG87RM-2450 (in progress) 2AG87RM-915 (in progress)
Industry Canada (IC)	21411-RM2450 (in progress) 21411-RM915 (in progress)
CE	Fully Certified (in progress)

Regulatory Requirements

Designed and verified to meet various regulatory requirements. Formal testing and approval are required for the Integrator's antenna type. The Integrator is responsible for obtaining all regulatory approvals in target markets for the finished product.

RoHS/WEEE Compliance

Yes. 100% Recyclable/Biodegradable packaging

ADDITIONAL RF SPECIFICATIONS

MCS Rate	Modulation	Combined Output Power (dBm)	Sensitivity (dBm)	UDP Throughput (Mbps)
0	BPSK (1/2)	30	-93	5.4
1	QPSK (1/2)	29	-91	10.62
2	QPSK (3/4)	29	-89	15.66
3	16-QAM (1/2)	29	-87	20.52
4	16-QAM (3/4)	28	-83	29.88
5	64-QAM (2/3)	27	-79	38.88
6	64-QAM (3/4)	26	-77	43.11
7	64-QAM (5/6)	24	-75	47.34
8	BPSK (1/2)	30	-90	10.53
9	QPSK (1/2)	29	-88	20.43
10	QPSK (3/4)	29	-86	29.7
11	16-QAM (1/2)	29	-84	38.52
12	16-QAM (3/4)	28	-80	54.72
13	64-QAM (2/3)	27	-76	69.3
14	64-QAM (3/4)	26	-74	76.14
15	64-QAM (5/6)	24	-72	82.8

Note 1: Performance based on 20-MHz bandwidth

Note 2: Sensitivity and throughput are approximately proportional to bandwidth.

FCC Statement

Changes or modifications not expressly approved by the party responsible for compliance could void the user's authority to operate the equipment.

This equipment has been tested and found to comply with the limits for a Class B digital device, pursuant to Part 15 of the FCC Rules. These limits are designed to provide reasonable protection against harmful interference in a residential installation. This equipment generates uses and can radiate radio frequency energy and, if not installed and used in accordance with the instructions, may cause harmful interference to radio communications. However, there is no guarantee that interference will not occur in a particular installation. If this equipment does cause harmful interference to radio or television reception, which can be determined by turning the equipment off and on, the user is encouraged to try to correct the interference by one or more of the following measures:

- Reorient or relocate the receiving antenna.
- Increase the separation between the equipment and receiver.
- Connect the equipment into an outlet on a circuit different from that to which the receiver is connected.
- Consult the dealer or an experienced radio/TV technician for help

This device complies with part 15 of the FCC rules. Operation is subject to the following two conditions (1) this device may not cause harmful interference, and (2) this device must accept any interference received, including interference that may cause undesired operation

IC Statement

This device complies with Industry Canada's licence-exempt RSSs. Operation is subject to the following two conditions:

1. This device may not cause interference; and
2. This device must accept any interference, including interference that may cause undesired operation of the device.

The term "IC: " before the certification/registration number only signifies that the Industry Canada technical specifications were met. This product meets the applicable Industry Canada technical specifications.

Le présent appareil est conforme aux CNR d'Industrie Canada applicable aux appareils radio exempts de licence. L'exploitation est autorisée aux deux conditions suivantes : (1) l'appareil ne doit pas produire de brouillage, et (2) l'utilisateur de l'appareil doit accepter

tout brouillage radioélectrique subi, même si le brouillage est susceptible d'en compromettre le fonctionnement

CE Statement

This is a Class A product. In a domestic environment, this product may cause radio interference, in which case the user may be required to take adequate measures.

CAUTION: To comply with the Europe CE requirement, this device must be installed with CE certified computer equipment which meet with Class A limits. Be aware that outdoor installations require special attention and will only be handled by trained and qualified installation personnel.

All cables used to connect this device must be shielded and grounded. Operation with non-certified computers or incorrect cables may result in interference to other devices or undesired effects to the product. Particular attention has to be given allowed operational frequencies.

Mouser Electronics

Authorized Distributor

Click to View Pricing, Inventory, Delivery & Lifecycle Information:

[Doodle Labs:](#)

[RM-1700-22M3](#)